

Plantronics Savi W740 FAQ

Q. What do I do when I get Battery Low Level warning?

A. First, check your battery level - two way to check your battery level:

1) Check the status using the system Tray Icon on your PC - With Plantronics software installed, a headset icon will displaying battery status. A warning will be issued if your headset's battery is low.



2) Check the status using the Base - When the system is idle, short press the base subscription button once to get feedback on the headset battery level. The computer, mobile and desk phone button LED's will light up, indicating your headset battery level.

Q. How do I fix the echo in my Plantronics W740 wireless headset?

A. Wireless Headset echo is very common and it's a simple adjustment fix. Depending on your telephone's original volume, you will need to fine tune your wireless headset. with any one of the following steps:

- 1) For most telephones the correct setting is position 3 (you can try other settings if still doesn't work)
- 2) If the audio level is too low, increase the headset volume. If your speaking volume is too low for your listener, adjust the position of the headset to make sure the microphone is as close as possible to your mouth.
- 3) On the Plantronics W740 Savi base, lower the speaking and/or listening volume to a level where it no longer echo's.
- 4) Adjust the configuration switch on the base until a dial tone is heard. The default A works for most phones.

Q. I don't hear a dial tone in my Plantronics Savi W740?

A. If you don't hear a dial-tone, try any of these following adjustments:

- Make sure your headset is fully charged (charge your new headset overnight before using)
- Make sure your headset is subscribed to the base if you have spare or new headset.
- On the base of the W740, Press the base desk phone button (see below):



Press the call control button on the headset to open the audio link from the headset to the device (see picture below):

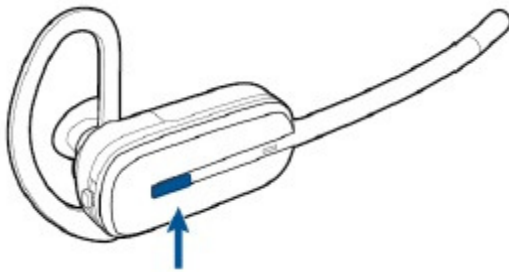

- Make sure the handset lifter is lifting the handset high enough to operate the hookswitch - adjust the height setting if necessary.
- Change the configuration switch on the base until a dial tone is heard. The default A works for most phones - but not always.
- Fine tune the Savi W740 headset volume level with the headset call control button. If the wireless headset volume is still too low, adjust the desk phone listening volume on the base.

Q. My Plantronics Savi W740 sound is distorted, what do I do?

A. Try any of the following:

- If your telephone has a volume control, lower it until the distortion disappears.
- On the Savi W740 base, turn down the out-going and/or listening volume. For most telephones the setting is position 3 (but not always)
- If the distortion is still present, adjust the headset volume control to lower the headset speaker volume.
- Check and make sure there is 12 inches between your base and your computer (or other electronic device such as an electronic calculator), and 6 inches between your base and telephone

Q. How do I set the wireless headset range of my Plantronics W740 and why do I need to change it?

Changing the range setting can help with your wireless headset audio quality, improve user density (more wireless headsets in the same office) or restrict range of users. The distance range settings are define as:

- High Range - Up to 350 feet
- Medium Range - Up to 150 feet
- Low Range - Up to 50 feet

Note: If you frequently use your W740 away from your base, you may experience a decrease in talk time due to the extra battery power it requires to communicate with the base.

With the system not in use, press the subscription (1) and desk phone (2) buttons simultaneously for 3 seconds. The desk phone button flashes green for high range.

To change to medium range setting, press the subscription button again for 3 seconds. The desk phone button flashes yellow.

To change to the low range setting, press the subscription button again for 3 seconds. The desk phone button flashes red.

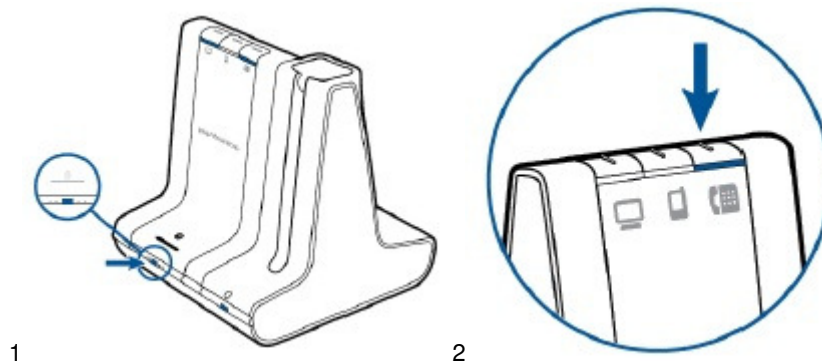

Q. How do I set W740 with my Bluetooth device like my cell phone?

A. Your Bluetooth enable cell phone can be paired to multiple Bluetooth headsets, but it can only be used with one device at a time. The following are instructions for pairing your cell phone to the base.

1. Press down and hold the Bluetooth pairing button for 4 seconds on the Savi base until the indicator light flashes red and blue. The base will remain in this mode for 10 minutes. If it goes off, you will need to press it again.
2. Place the Bluetooth device into search mode. Select Savi 7xx from the list of found devices.
3. When prompted, type "0000" as the passcode
4. The Bluetooth indicator LED on the Savi W740 base will turn solid blue when the base has an active connection with the Bluetooth device.

Filename: Savi-W740_FAQ
Directory: C:\Users\Lee\Documents\Comfort\Web Page
Backup\Public\Plantronics\images
Template: C:\Users\Lee\AppData\Roaming\Microsoft\Templates\Normal.dot
Title:
Subject:
Author: Lee
Keywords:
Comments:
Creation Date: 7/14/2011 4:46:00 PM
Change Number: 3
Last Saved On: 7/14/2011 5:34:00 PM
Last Saved By: Cox
Total Editing Time: 7 Minutes
Last Printed On: 7/14/2011 5:34:00 PM
As of Last Complete Printing
Number of Pages: 3
Number of Words: 807 (approx.)
Number of Characters: 4,600 (approx.)